

G-Series

DIN-RAIL CIRCUIT BREAKER

The G-Series hydraulic-magnetic circuit breaker insures maximum protection by integrating wiping contacts for longevity; a common trip linkage between poles; a unique terminal bus connection system; and optional integrated auxiliary switch. It is also suitable for reverse feed and provides finger safe terminals. This DIN rail mount circuit breaker accommodates either a 35mm x 7.5mm, or a 35mm x 15mm symmetrical din rails.

G-Series DIN Rail Circuit Breaker:

UL 489 Listed: 1 to 3 poles; 1-50 Amps; 125 VDC, 240 VAC;

UL 1077 Recognized: 1 to 4 poles; 0.1-63 Amps; 80 VDC, 240 VAC/480VAC; cUL, TUV, CSA & CCC.

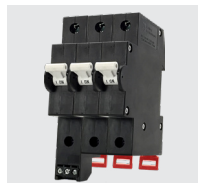

Product Highlights:

- DIN Rail Mounting
- UL 489 Listed
- UL 1077 Recognized, cUL, TUV, CSA & CCC
- Wiping Contacts
- Common Trip Linkage Between Poles
- Optional Integrated Auxiliary Switch

Typical Applications:

- Renewable Energy
- Telecom
- Control Panels
- Industrial Automation Controls



Carling Technologies®

Innovative Designs. Powerful Solutions.

Techna

www.techna.co.uk

G-Series

DESIGN FEATURES

TERMINAL BARRIERS

Meet UL 489 Spacing Requirements

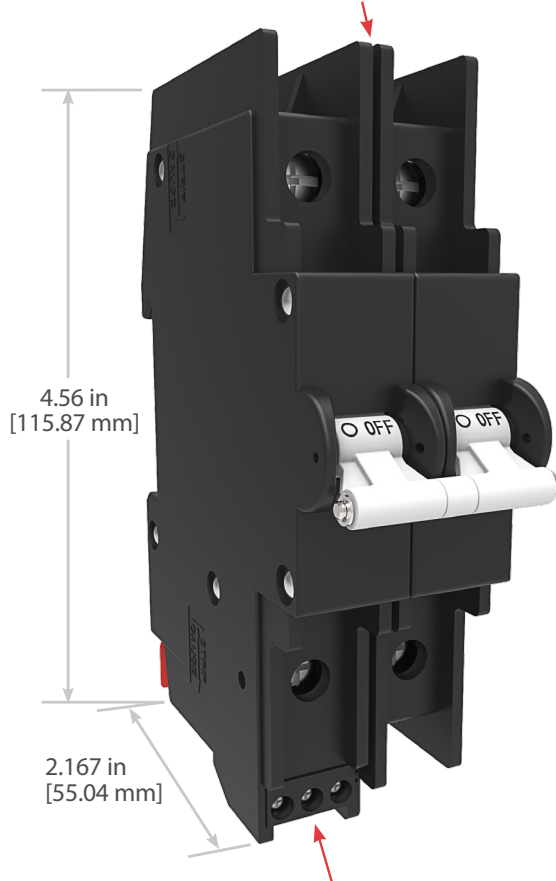

OPTIONAL AUXILIARY SWITCH

Provides Breaker Status Indication



DIN RAIL MOUNTING

Snap on Back Panel Rail Mounting for either 35 x 7.5 mm or 35 x 15 mm

DIN RAIL LOCK

Secures Circuit Breaker to the DIN Rail

Auxiliary Switch with Internal Connector



Advantages:

- Pre-wiring is possible
- Easy interchangeable
- Time saving solution
- Various connection methods
- Many different plugs

Example Plugs:

Spring clamp terminals

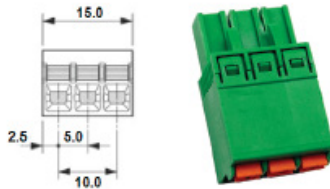

Dimensions in mm

- | | |
|--------------------------------------|----------------------------|
| Wire size solid wire | 0.2 - 1.5 mm ² |
| Wire size stranded wire | 0.2 - 2.5 mm ² |
| Wire size stranded wire with ferrule | 0.25 - 1.5 mm ² |
| Wire stripping length | 10 mm |

Screw terminals



Screw terminals 45° angle



The auxiliary contact with internal connector can be used with Phoenix CombiCon plugs. Phoenix item number internal connector: 1753453. The circuit breaker is standard delivered without plugs.

*Manufacturer reserves the right to change product specification without prior notice.

Electrical Tables

Table A: Lists UL Recognized, CSA Accepted and TUV Certified capabilities as a Component Supplementary Protector.

G-SERIES TABLE A: COMPONENT SUPPLEMENTARY PROTECTORS									
Circuit Configuration	Voltage				Current Rating Full Load Amps	Short Circuit Capacity (Amps)		Application Codes	
	Max Rating	Frequency	Phase	Minimum Poles		Without Backup Fuse		UL	CSA
						UL/CSA	TUV		
Series	80	DC	---	1	.1 - 63	3000	1500	TC1, OL1, U1	TC1, OL1, U1
	240	50 / 60	1	1	.1 - 63	3000	1500	TC1, OL1, U1	TC1, OL1, U1
	240	50 / 60	1	2	.1 - 63	3000	1500	TC1, OL1, U1	TC1, OL1, U1
	480	50 / 60	3	3	.1 - 63	1500	415V, 1000	TC1, OL1, U1	TC1, OL1, U1

Table B: Lists UL Listed (489) configuration and performance capabilities.

G-SERIES TABLE B: UL 489 LISTED BRANCH CIRCUIT BREAKERS						
Circuit Configuration	Voltage				Current Rating Full Load Amps	Interrupting Capacity (Amps RMS)
	Max Rating	Frequency	Phase	Poles		
Series	80	DC	---	1	1 - 50	5000
	125	DC	---	2	1 - 50	5000
	120	50 / 60	1	1	1 - 50	5000
	120 / 240	50 / 60	1	1 - 3 ¹	1 - 50	5000
	240	50 / 60	1	1	1 - 25	5000

¹ One pole out of the three poles must be a neutral break.

Electrical

Maximum Voltage AC: 240VAC (single pole), 480VAC (3 poles, additional pole shall be dedicated for neutral break) DC: 80VDC (single pole & multipole) 0.1 – 63A. Other ratings available, see Ordering Scheme.

Current Rating (optional) Integrated, load side. SPST, 3A – 125VAC, 2A – 30VDC. Auxiliary switch senses the on & off position of circuit breaker handle, as well as contact arm position. Switch connections are screw terminals.

Auxiliary Switch Rating Minimum of 100 Megohms at 500 VDC

Insulation Resistance Dielectric Strength UL, CSA: 1960 V 50/60 Hz for one minute between all electrically isolated terminals. G-Series circuit breakers comply with the 8mm spacing and 3750V 50/60 Hz dielectric requirements from hazardous voltage to operator accessible surfaces, between adjacent poles and from main circuits to auxiliary circuits per Publications EN 60950 and VDE 0805.

Resistance, Impedance Values from Line to Load Terminal - based on series trip circuit breaker.

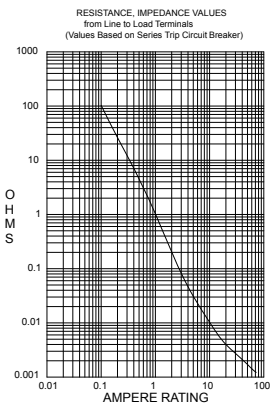

CURRENT (AMPS)	TOLERANCE (%)
0.10 - 5.0	15
5.1 - 20.0	25
20.1 - 63.0	35

Mechanical

Endurance 10,000 ON-OFF operations @ 6 per minute; with rated current & voltage. All G-Series circuit breakers will trip on overload, even when actuator is forcibly held in the ON position.

Trip Free

Trip Indication The operating actuator moves positively to the OFF position when an overload causes the breaker to trip. With mid-trip, the handle moves to the mid position on electrical trip of the circuit breaker. With mid trip handle with alarm switch, handle moves to the mid position and the alarm switch actuates when the circuit breaker is electrically tripped.

Physical

Number of Poles 1 pole ≤ 63A, 2 poles ≤ 63A per pole

Weight Approx. 172 grams/pole (4.13 oz).

Standard Colors Housing: Black

Environmental

Designed in accordance with requirements of specification MIL-PRF-55629 & MIL-STD-202 as follows:

Shock Withstands 100 Gs, 6ms sawtooth while carrying rated current per Method 213, Test Condition "I". Instantaneous and ultrashort curves tested @ 90% of rated current. Withstands 0.060" excursion from 10-55 Hz & 10 Gs 55-500 Hz, @ rated current per Method 204C, Test Cond. A. Instantaneous & ultrashort curves tested @ 90% of rated current.

Vibration Method 106D, i.e., ten 24-hour cycles @ +25°C to +65°C, 80-98% RH. Method 101, Condition A (90-95% RH @ 5% NaCl Solution, 96 hrs).

Moisture Resistance Method 107D, Condition A (five cycles @ -55°C to +25°C to +85°C to +25°C).

Salt Spray

Thermal Shock

Operating Temperature -40°C to +85°C

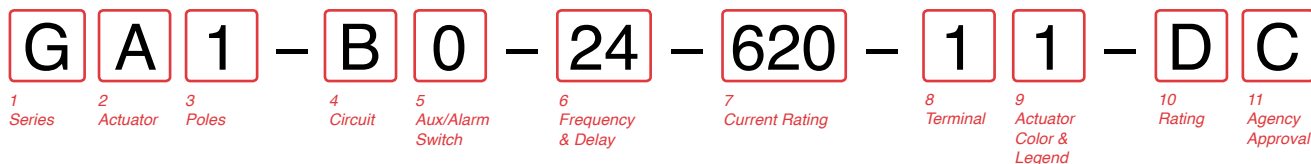

1 SERIES
G

2 ACTUATOR
A Handle, one per pole
S Mid-Trip Handle, one per pole

3 POLES
1 One 3 Three
2 Two 4 Four

4 CIRCUIT
A¹ Switch Only (no coil)
B Series Trip (current)

5 AUXILIARY / ALARM SWITCH ³
0 without Aux Switch
1 S.P.D.T., Screw Terminal
3 S.P.D.T. Screw Terminal (Gold Contacts)
5 Plug-in Terminal
6 Plug-in Terminal (Gold Contacts)

6 FREQUENCY & DELAY

03 Switch Only	26 50/60 Hz Long
10 DC, Instantaneous	42 50/60 Hz High-inrush Short ²
11 DC, Ultra Short	44 50/60 Hz High-inrush Medium
12 DC, Short	46 50/60 Hz High-inrush Long
14 DC, Medium	52 DC High-inrush Short
16 DC, Long	54 DC High-inrush Medium
20 50/60 Hz Instantaneous	56 DC High-inrush Long
21 50/60 Ultra Short	
22 50/60 Hz Short	
24 50/60 Hz Medium	

7 CURRENT RATING (AMPERES)

CODE	AMPERES						
210	0.100	410	1.000	470	7.000	617	17.000
220	0.200	512	1.250	475	7.500	618	18.000
225	0.250	415	1.500	480	8.000	620	20.000
230	0.300	517	1.750	485	8.500	622	22.000
235	0.350	420	2.000	490	9.000	624	24.000
240	0.400	522	2.250	495	9.500	625	25.000
245	0.450	425	2.500	610	10.000	630	30.000
250	0.500	527	2.750	710	10.500	635	35.000
255	0.550	430	3.000	611	11.000	640	40.000
260	0.600	435	3.500	711	11.500	650	50.000
265	0.650	440	4.000	612	12.000	655	55.000
270	0.700	445	4.500	712	12.500	660	60.000
275	0.750	450	5.000	613	13.000	663	63.000
280	0.800	455	5.500	614	14.000		
285	0.850	460	6.000	615	15.000		
290	0.900	465	6.500	616	16.000		

8 TERMINAL
1 Screw Terminal

9 ACTUATOR COLOR & LEGEND

Actuator Color	I-O	ON-OFF	Dual	Legend Color
White	A	B	1	Black
Black	C	D	2	White
Red	F	G	3	White
Green	H	J	4	White
Blue	K	L	5	White
Yellow	M	N	6	Black
Gray	P	Q	7	Black
Orange	R	S	8	Black

10 APPLICATION RATING
B 125 VDC ⁵
D 240 VAC
H 480 VAC ⁴
M 80 VDC

11 AGENCY APPROVAL
A Without Approvals
C UL Recognized, CSA Accepted
E UL Recognized, CSA Accepted, TUV Certified, CCC Certified

Notes:
1 Switch only circuit only available when tied to a protected pole (Circuit code B)
- for .2 to 30 amps select current code 630
- for 31 to 50 amps select current code 650
- for 51 to 63 amps select current code 663
- Use delay 03 for all switch only poles
2 Hi Inrush Delays limited to 50A max
3 On multi-pole breakers one auxiliary switch is supplied , mounted in the extreme left pole when viewed from front of panel
4 480 VAC rating requires 3 or 4 pole break 3Φ and 2 pole break 1Φ
5 This construction is polarity sensitive when constructed as a single pole unit, 125 VDC is only available without agency approvals

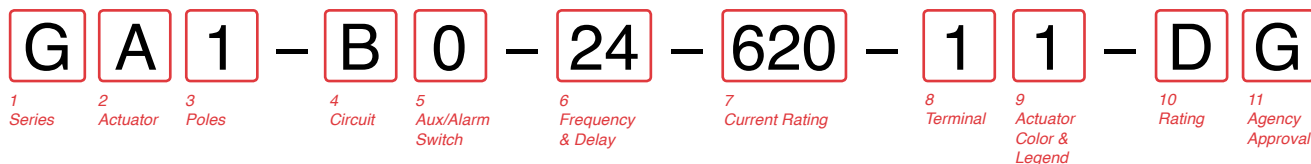

1 SERIES
G

2 ACTUATOR
A Handle, one per pole
S¹ Mid-Trip Handle, one per pole

3 POLES
1 One
2 Two
3 Three

4 CIRCUIT
B Series Trip (current)

5 AUXILIARY / ALARM SWITCH³
0 without Aux Switch
1 S.P.D.T., Screw Terminal
3 S.P.D.T. Screw Terminal (Gold Contacts)
5 Plug-in Terminal
6 Plug-in Terminal (Gold Contacts)

6 FREQUENCY & DELAY

11 DC, Ultra Short	42 50/60 Hz High-inrush Short ⁴
12 DC, Short	44 50/60 Hz High-inrush Medium ⁴
14 DC, Medium	46 50/60 Hz High-inrush Long ⁴
16 DC, Long	52 DC High-inrush Short ⁴
21 50/60 Ultra Short	54 DC High-inrush Medium ⁴
22 50/60 Hz Short	56 DC High-inrush Long ⁴
24 50/60 Hz Medium	
26 50/60 Hz Long	

7 CURRENT RATING (AMPERES)

CODE	AMPERES				
410	1.000	445	4.500	610	10.000
512	1.250	450	5.000	710	10.500
415	1.500	455	5.500	611	11.000
517	1.750	460	6.000	711	11.500
420	2.000	465	6.500	612	12.000
522	2.250	470	7.000	712	12.500
425	2.500	475	7.500	613	13.000
527	2.750	480	8.000	614	14.000
430	3.000	485	8.500	615	15.000
435	3.500	490	9.000	616	16.000
440	4.000	495	9.500	617	17.000

8 TERMINAL
1 Screw Terminal

9 ACTUATOR COLOR & LEGEND

Actuator Color	ON-OFF	Dual	Legend Color
White	B	1	Black
Black	D	2	White
Red	G	3	White
Green	J	4	White
Blue	L	5	White
Yellow	N	6	Black
Gray	Q	7	Black
Orange	S	8	Black

10 APPLICATION RATING
B 125 VDC⁵
C 120/240 VAC⁶
D 240 VAC⁷
K 120 VAC⁸
M 80 VDC⁹

11 AGENCY APPROVAL
A Without Approvals
G UL489 Listed

Notes:

- 1 Mid-trip Handle(s) available at 1 pole unit and 2 pole unit only.
- 2 Third pole of a 3 pole unit is switch only pole.
- 3 On multi-pole breakers one auxiliary switch is supplied, mounted in the extreme left pole when viewed from front of panel.
- 4 Hi Inrush Delays limited to 50A maximum.
- 5 125VDC for 2 pole unit only.
- 6 120/240VAC for 2 pole and 3 pole unit only. Limited to 50A maximum, and third pole of a 3-pole unit is switch only pole.
- 7 240VAC for 1 pole unit only, limited to 25A maximum
- 8 120VAC for 1 pole unit only, limited to 50A maximum.
- 9 80VDC for 1 pole unit only

Dimensional Specifications: in. [mm]

1 POLE WITHOUT AUXILIARY SWITCH

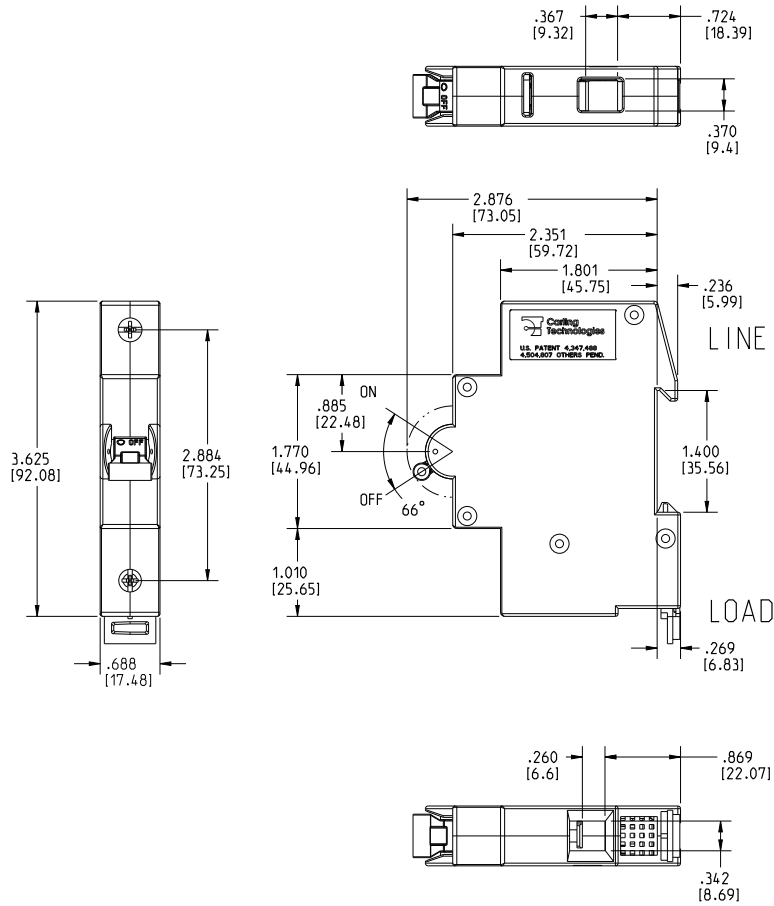

1 POLE WITH AUXILIARY SWITCH (PLUG-IN TERMINAL BLOCK)

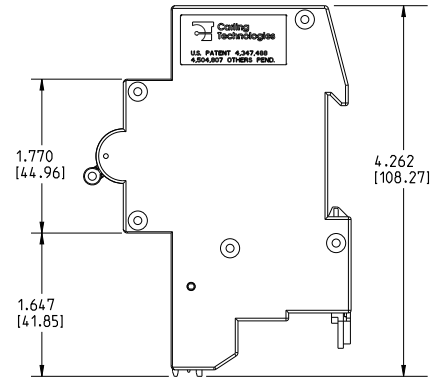

1 POLE WITH AUXILIARY SWITCH (SCREW TERMINAL BLOCK)

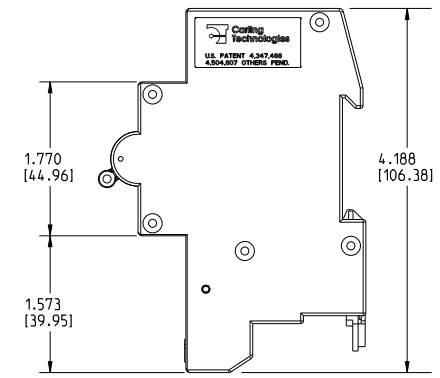

MULTIPLE POLES WITH AUXILIARY SWITCH (PLUG-IN TERMINAL BLOCK)

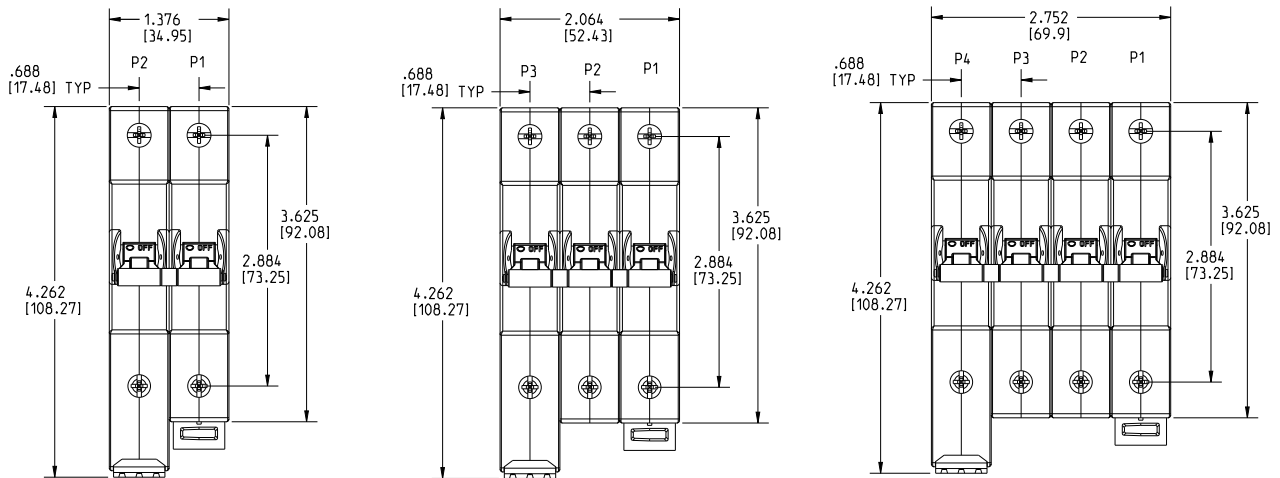

- Notes:
- All dimensions are in inches [millimeters].
 - Tolerance ± 0.020 [51] unless otherwise specified.

Dimensional Specifications: in. [mm]

1 POLE WITHOUT AUXILIARY SWITCH

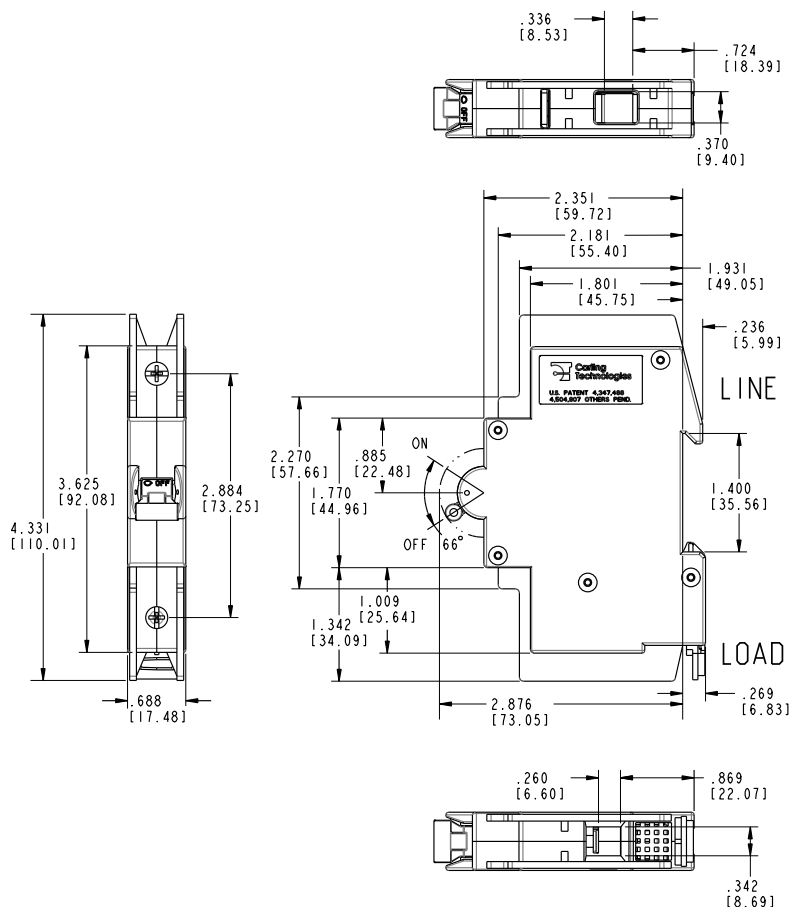

1 POLE WITH AUXILIARY SWITCH (PENDING)
(PLUG-IN TERMINAL BLOCK)

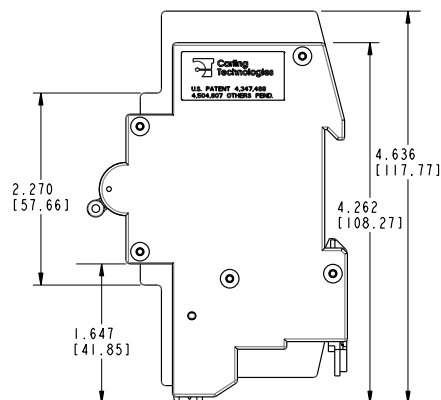

1 POLE WITH AUXILIARY SWITCH (PENDING)
(SCREW TERMINAL BLOCK)

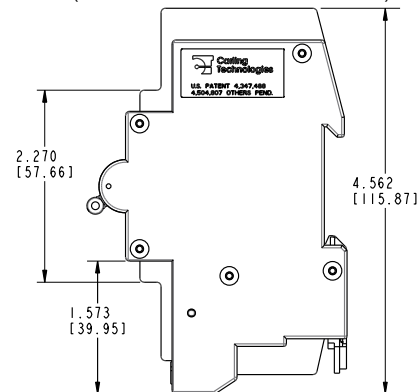

MULTIPLE POLES WITH AUXILIARY SWITCH (PENDING) (PLUG-IN TERMINAL BLOCK)

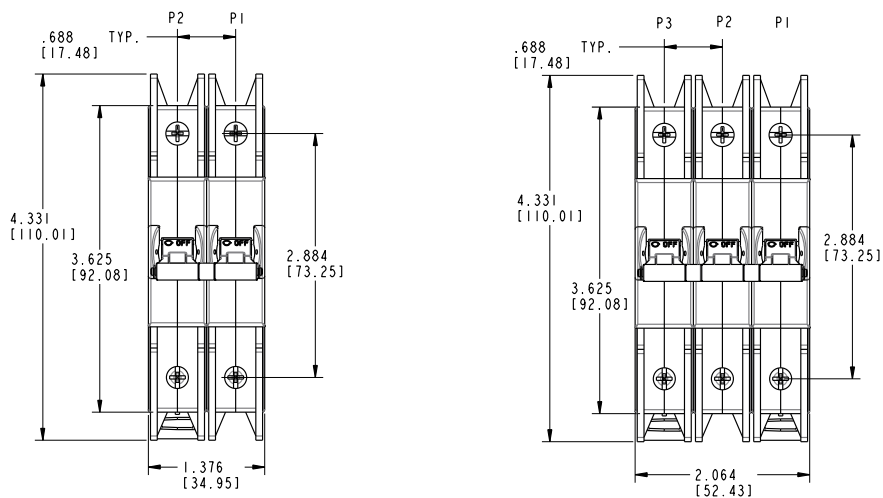

Notes:

- 1 All dimensions are in inches [millimeters].
- 2 Tolerance ± 0.020 [0.51] unless otherwise specified.

UL RECOGNIZED

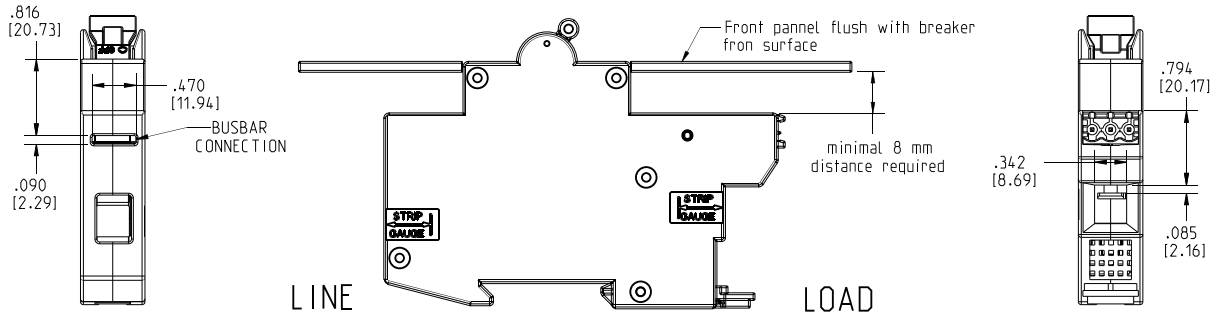

UL489

